

U Type Gleitbuchse Führungseinheiten WUC Serie/U Guide With Bush Guides For ISO 15552 WUC- Series

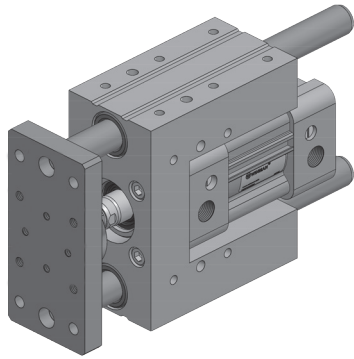

Spezifikation/ Specification

Bohrungsgröße/ Bore Size	32	40	50	63
Temperatur/Temperature	-20 ~ +80 °C			
Geschwindigkeitsbereich/ Speed Range	< 800 mm/s			

Technische Zeichnung/Technical Drawing

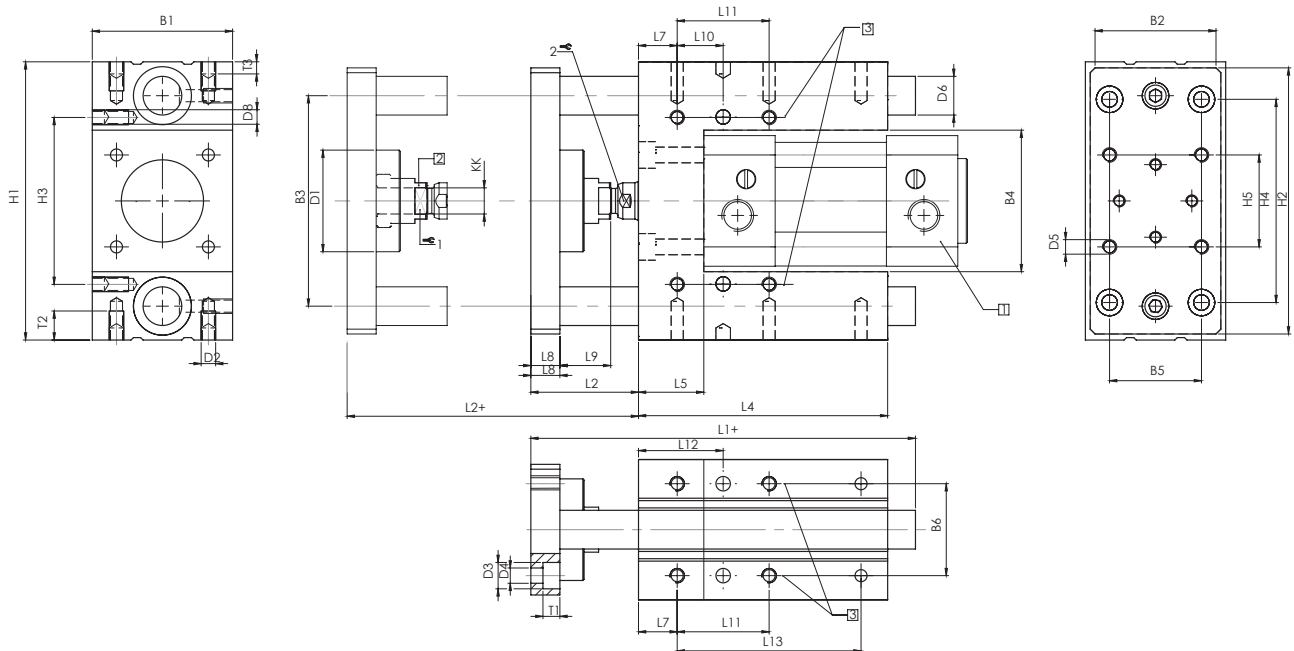

- 1 ISO 15552 ZYLINDER /ISO 15552 Cylinders
- 2 Kompensatorkupplung /Compensator coupling

Ø mm	B1 -0.3	B2	B3 ±0.15	B4	B5	B6 ±0.15	D1 Ø	D2	D3 Ø	D4 Ø	D5	D6 Ø	D8 Ø H9	H1 -0.4	H2	H3 ±0.15	H4	H5	KK	L1	L2 +5	L4	L5	L7	L8	L9	L12 ±0.1	L11 ±0.15	L13	T1	T2	1	2
32	50	45	74	50.0	32.5	32.5	42	M6	11	6.5	M6	12	6	97	95	61	78	32.5	M12X1.25	154	-	85	24	20	12	21	35.0	32.5	-	6	10.5	15	10
40	58	54	87	58.5	38.0	38.0	42	M6	11	6.5	M6	16	6	115	110	69	84	38.0	M12X1.25	159	-	103	27	16	12	21	35.0	38.0	-	7	12.0	15	14
50	70	63	104	70.5	46.5	46.5	58	M8	15	8.5	M8	20	6	137	130	85	100	46.5	M16X1.5	182	-	110	37	17	15	29.5	40.3	46.5	82	8	16.0	21	17
63	85	80	119	85	56.5	56.5	58	M8	15	8.5	M8	20	6	152	145	100	105	56.5	M16X1.5	222	-	145	38	20	15	29.5	50.0	56.5	113	8	16.0	21	17

Bestellnummer/Ordering Code

Model/Model	Führung/Guiding	Diameter/Diameter	Hub/Stroke
WUC	R	050	0100
führung typ U U Type Guiding	R :Lagerführung Bearing Guide B :Buchsenführung Bushing Guide	Kolben-Durchmesser (mm) Piston Dia	STROK (mm) Stroke